

AKIRA

makes life better

Air Conditional Service Manual



Большая библиотека технической документации

<https://splitsystema48.ru/instrukcii-po-ekspluatacii-kondicionerov.html>

каталоги, инструкции, сервисные мануалы, схемы.

Model:
AC-CA30HK

CONTENTS

SPECIFICATIONS.....	4
EXPLODED VIEW & PART LIST.....	6
WIRING DIAGRAM.....	10

SPECIFICATION

Model No.			AC-CA30HK	
Type			Cassette Type, Heat Pump	
Cooling Capacity (Btu/h)			24200	24200
Heating Capacity (Btu/h)			26600	26600
Rated Input (w)	Cooling		2700	2700
	Heating		2750	2750
PTC Heater Power (W)			2100	2100
Moisture Removal (L/H.r)			2.9	2.9
Air Circulation (CMH Max)			1100	1100
EER for Cooling (Btu/h.w)			9.0	9.0
COP for Heating (w/w)			2.8	2.8
Refrigerant			R22 (2400g)	R22 (2400g)
Volt/Phase/Hz			220-240V~/1P/50Hz	380V~/3P/50Hz
Rated Current (A)	Cooling		12.5	5.7
	Heating		12.8	5.8
	PTC Heater		9.6	5.0
LRA			76	82
Noise Level (dB (A))	Indoor Unit	High	46	46
		Low	40	40
	Outdoor Unit		60	60
Compressor type			Scroll	Scroll
Compressor Model No.			ZR34K3-PFJ	ZR34K3-TFD
Compressor MFG			Copeland	Copeland
Expansion Device			Capillary	Capillary
Evaporator			Copper and Aluminum Fin	
Condenser			Copper and Aluminum Fin	
LCD Wireless Remote Controller			Yes	Yes
Removable and Washable Panel			Yes	Yes
Washable Filter			Yes	Yes
24 Hours Timer			Yes	Yes
3 Speed Control			Yes	Yes
Auto Swing			Yes	Yes
Sleep Operation			Yes	Yes
Smart Function ("I Feel" Mode)			Yes	Yes
Auto Restart			Optional	Optional

Model No.		AC-CA30HK	
Water Discharge Indication		Yes	Yes
PTC Heater		Yes	Yes
Dimensions WxHxD (mm)	Panel	950x40x950	950x40x950
	Indoor Unit	840x220x840	840x220x840
	Outdoor Unit	890x793x362	890x793x362
Net Weight (Kg)	Indoor Unit	35	35
	Outdoor Unit	78	78
Packing Dimensions WxHxD (mm)	Panel	1030x130x1044	1030x130x1044
	Indoor Unit	960x346x974	960x346x974
	Outdoor Unit	1040x900x480	1040x900x480
Gross Weight (Kg)	Indoor Unit	41	41
	Outdoor Unit	88	88
Loading Capacity (40°/40° HC)		54/60	54/60

EXPLODED VIEW AND PART LIST

INDOOR UNIT

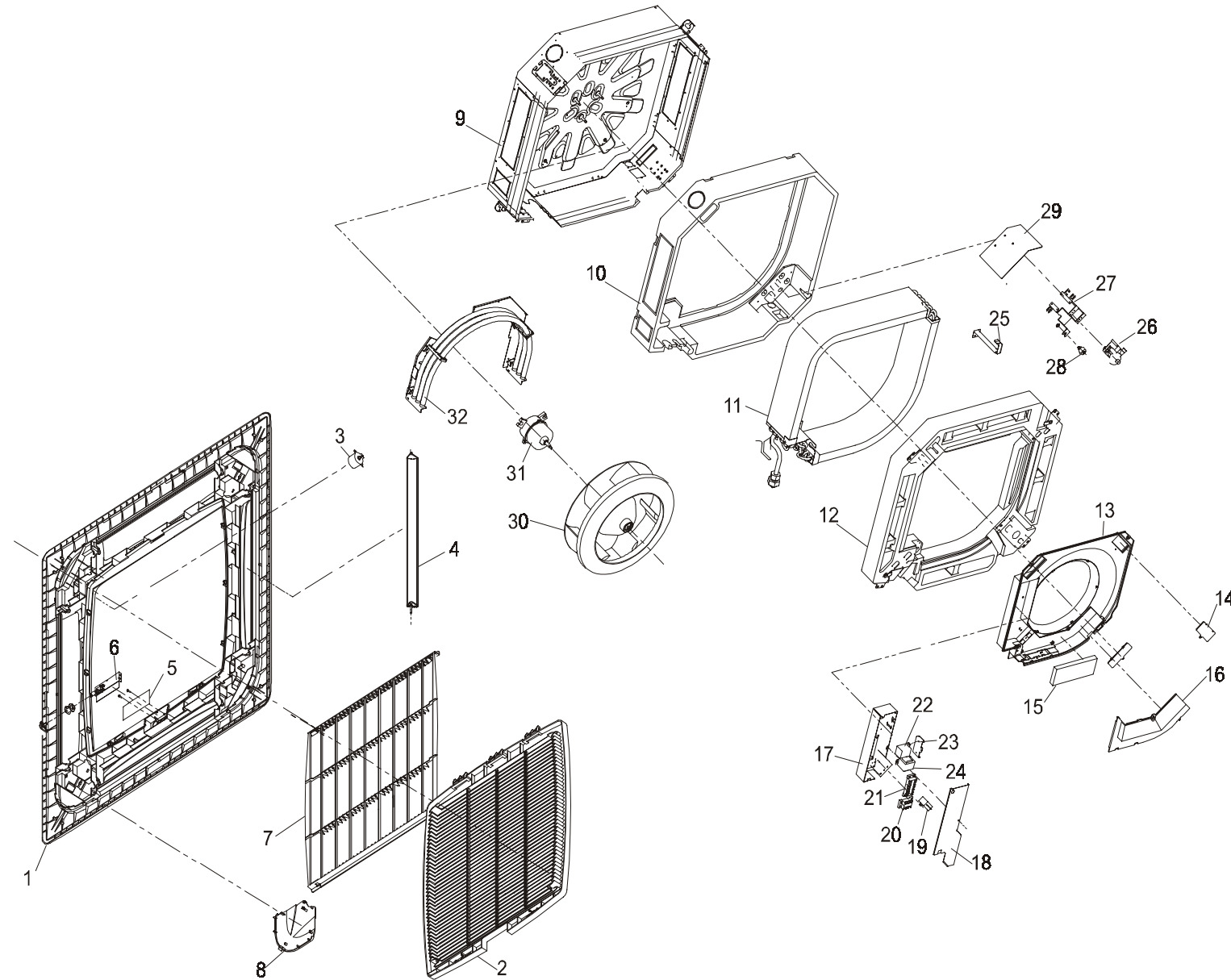

INDOOR UNIT

No.	Description	Part No.	Qty
1	Front Cover Assembly	1006559	1
2	Air Inlet Grille	1201185	1
3	Swing Motor	1402197	4
4	Louver	1201248	4
5	Display PCB	1409252	1
6	Display PCB Cover	2109229	1
7	Air Filter	130676	1
8	Corner Cover plate		
9	Cabinet Assembly		
10	Up Air Flow Volute		
11	Evaporator Assembly		
12	Drain Pan		
13	Air Deflector		
14	Access Cover		
15	Control PCB Assembly		
16	Control Box Cover		
17	Electrical Box		
18	Electrical Box Cover		
19	Fan Capacitor		
20	Terminal 3PUB		
21	Terminal 6P2		
22	Contactor		
23	Contactor Fixing Panel		
24	Transformer		
25	Evaporator Support		
26	Water Pump		
27	Water Pump Support		
28	Water Level Switch(Low)		
28a	Water Level Switch 1(High)		
29	Baffle Plate		
30	Indoor Fan		
31	Indoor Fan Motor		
32	Electric Heater		
33	Remote Controller		

Model No: AC-CA30HK
 Version 1.0

OUTDOOR UNIT

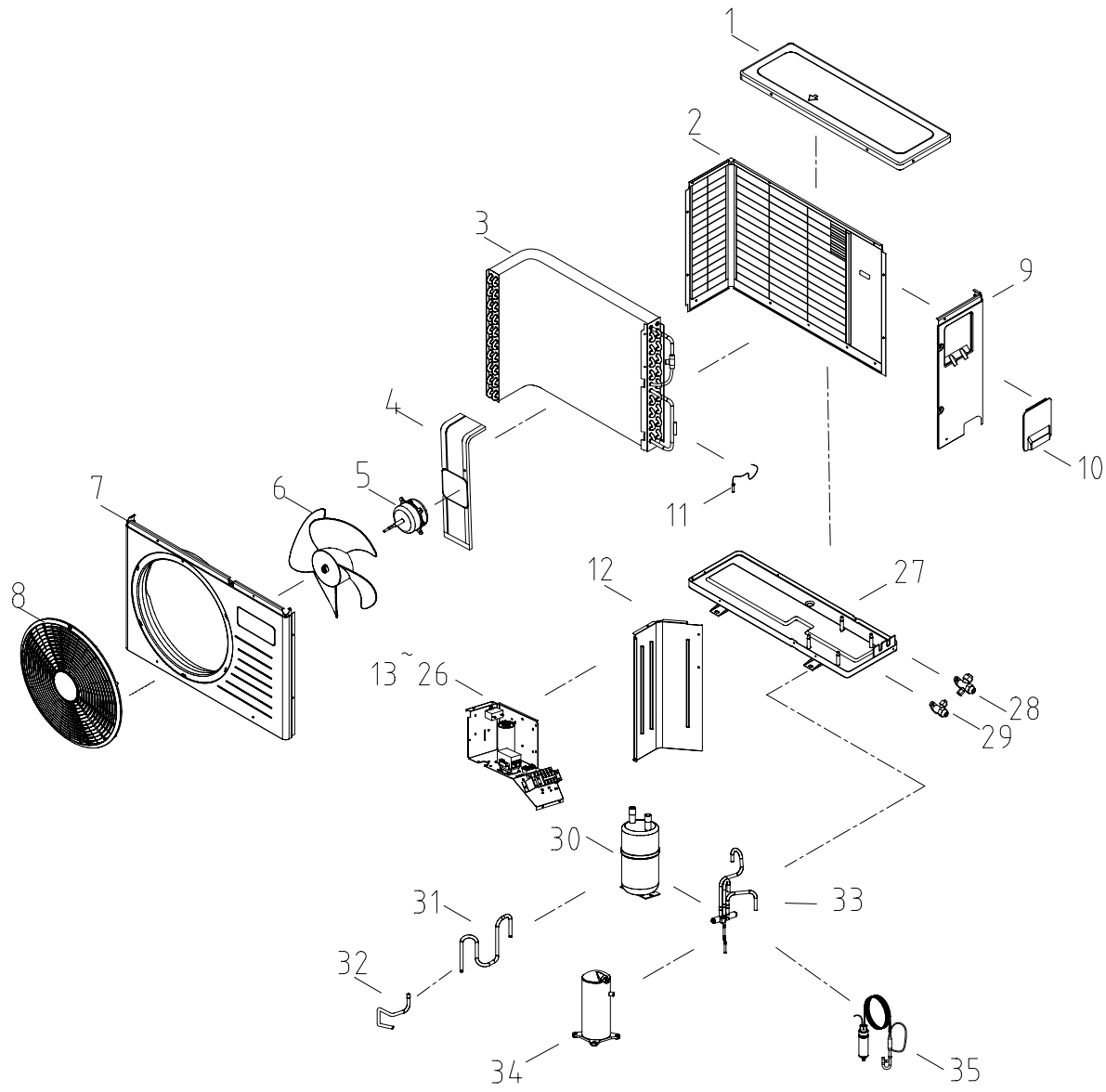

OUTDOOR UNIT

No.	Description	Part No	Qty
1	Top Cover	21093056	1
2	Rear Cover	21093059	1
3	Condenser	1302172	1
4	Motor Stay Bracket	11093021	1
5	Outdoor Fan Motor	14023007	1
6	Outdoor Fan	14023031	1
7	Cabinet	1105307	1
8	Fan Guard	21093069	1
9	Right Side Plate	21093058	1
10	Terminal Cover	21093054	1
11	Thermistor	11053010	1
12	Bulkhead	12033038	1
13	Electrical Assembly	1411937	1
14	Cord Fixing Board	11093016	1
15	Cord Clamp	12033012	1
16			
17	Terminal Board 4P2	15023004(A)	1
18	Terminal Board 5P3	150288	1
19	Terminal Board 2U	150217	1
20	Fan motor Capacitor	14113057	1
21	Compressor Capacitor	14113044	1
22	AC Contactor	1411941	1
23	Power Supply Cord	1501458	1
24			
25	Phase order board	N/A	1
26	Electrical Box	12033024	1
27	Chassis	12033041	1
28	3 Way valve	8130914	1
29	2 Way valve	8130918	1
30	Accumulator Assembly	813053	1
31	Suction Pipe	81303559	1
32			
33	4 Way Valve	1411585	1
33a	4 Way Valve Coil	1411458	1
34	Compressor	1304281	1
35	Capillary Assembly	13031945	1

WIRING DIAGRAM

Indoor unit

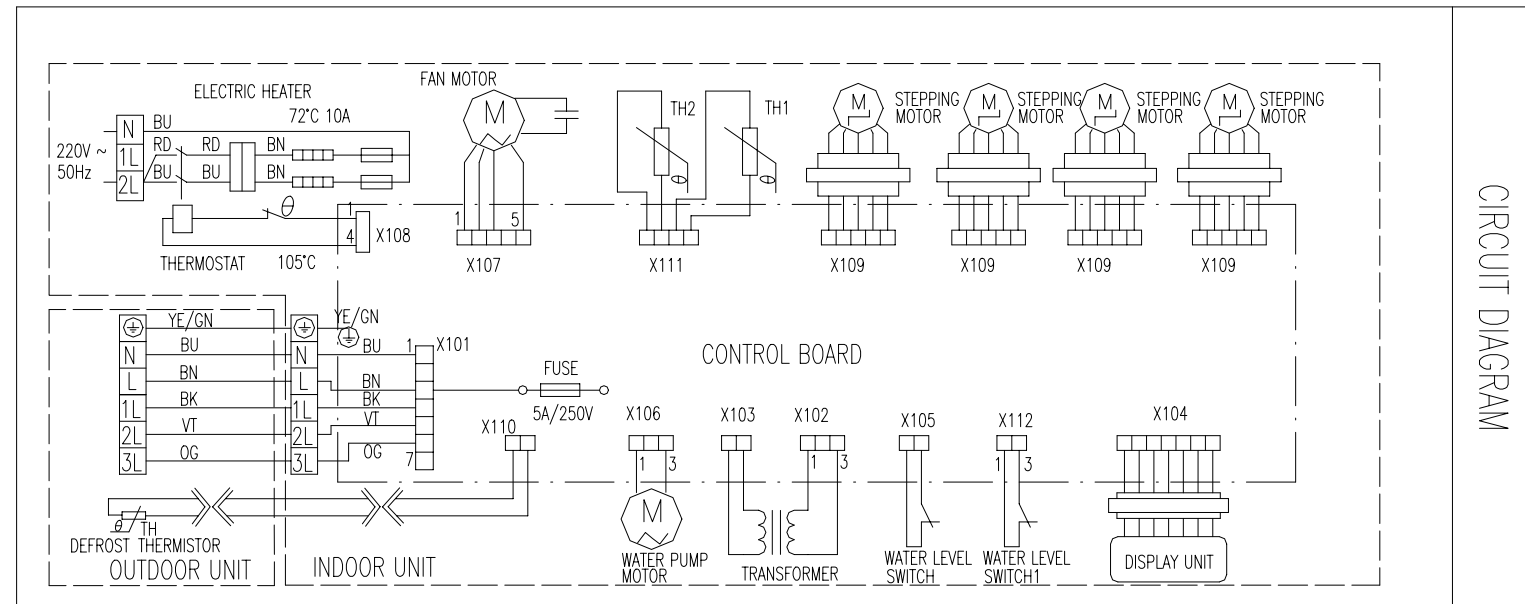

Outdoor unit

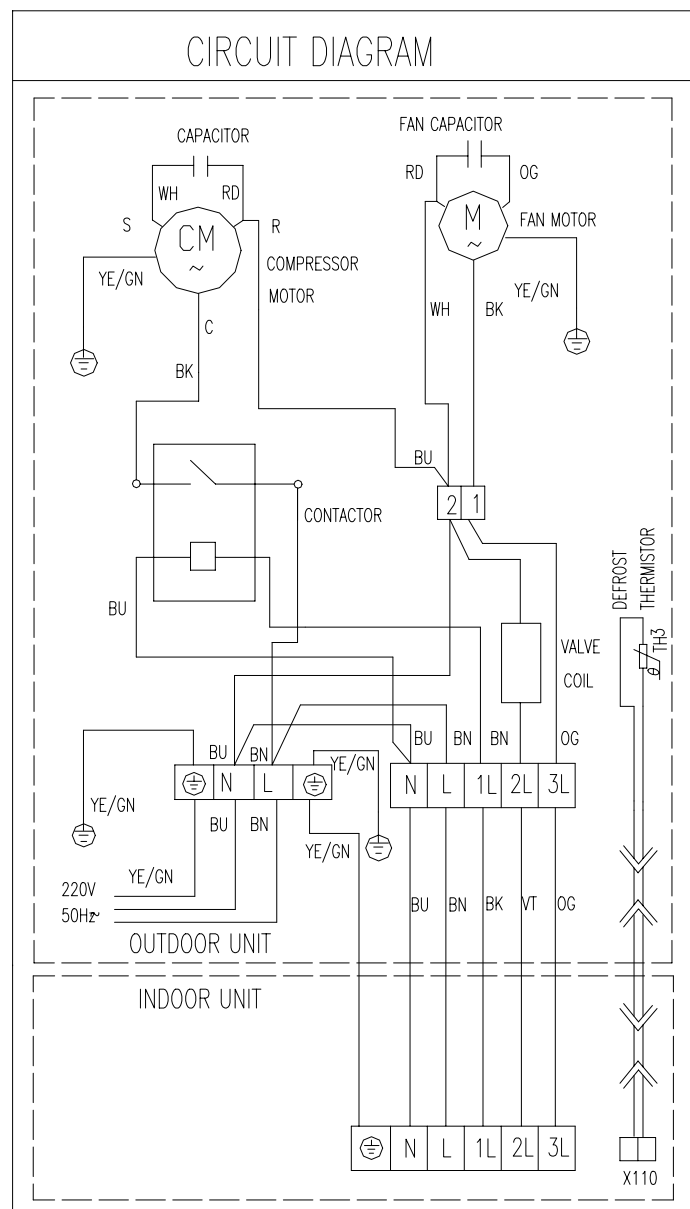



AKIRA
makes life better

Большая библиотека технической документации

<https://splitsystema48.ru/instrukcii-po-ekspluatcii-kondicionerov.html>

каталоги, инструкции, сервисные мануалы, схемы.